



www.navirnet.net

NAVIRNET SL - SPAIN

SASA-172

At this moment we FINISH the development of our SASA-172. The certifiable version of the SASA-172 comes with a full fuselage to create a very realistic experience when flying in our professional Flight Simulator. Since all our products are developed as high quality replica's of the original product, the fuselage also needs to be as realistic as possible.



Navirnet S.L.
39529 Ruiseñada,
Comillas, Cantabria.
Tel/Fax: +34 942722059
navirnet@navirnet.net



NAVIRNET SL - SPAIN

www.navirnet.net

For the first prototype we used heavy duty fiber glass, but it is very difficult and time consuming to use polyester for serial production. So we decided to use vacuum forming, like we also do for our glareshield. Using vacuum forming, we can design the exterior and interior of the fuselage as realistic as in the real aircraft.



Navirnet S.L.
39529 Ruiseñada,
Comillas, Cantabria.
Tel/Fax: +34 942722059
navirnet@navirnet.net



NAVIRNET SL - SPAIN

www.navirnet.net

Here you can find some images of the production process. We expect the fuselage to be ready and available within one month. The fuselage will also be available as a separate product.

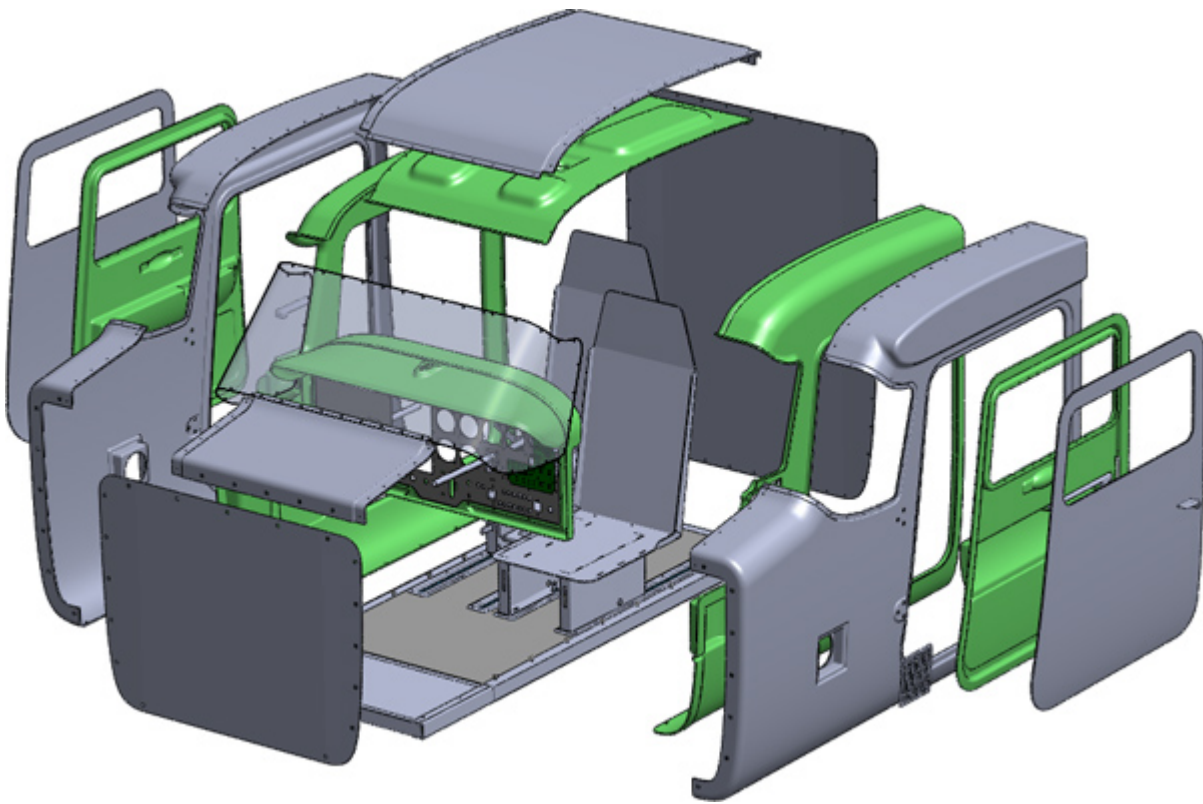

First we designed all the elements for the full fuselage using 3D cad software

Navirnet S.L.
39529 Ruiseñada,
Comillas, Cantabria.
Tel/Fax: +34 942722059
navirnet@navirnet.net



NAVIRNET SL - SPAIN

www.navirnet.net



From these files, foam molds are produced using a computerised mill. In the image above you see the interior of the SASA-172 and in the image above you see one of the doors.



Finally, one of the molds for one side of the fuselage. As you can see, these molds are very big.

The liquid aluminum is poured in one of the molds.

Once the mold has been filled with liquid aluminum, it has to cool down for a day or two, before the "sand" mold can be taken apart. When all the sand has been removed, we finally have a vacuum mold.

Using a big vacuum forming machine, the parts of the SASA-172F fuselage are being formed. Big ABS sheets are being heated in this machine, before forming them around the aluminum mold using vacuum technique.



navirnet@navirnet.net



NAVIRNET SL - SPAIN

www.navirnet.net

Our first product



And this is what your view will be, sitting in one of our SASA-172 Flight Simulators.

Also ask for the "cristal cockpit" configuration.

Navirnet S.L.
39529 Ruisseñada,
Comillas, Cantabria.
Tel/Fax: +34 942722059
navirnet@navirnet.net



NAVIRNET SL - SPAIN

www.navirnet.net

The SASA-172 is designed to be used at home or at flight schools to train students using the aircraft and to learn them to recognize the function of all instruments present in a fully IFR equipped Cessna 172 Skyhawk aircraft and to experience all aspects of flying single engine aircraft.

The SASA-172 can be placed onto a table or in a full cockpit configuration

Flight Simulator Software

The SASA-172 is controlled via Microsoft Flight Simulator (version 2004/FS9 or FSX).

The SASA-172 Flight Simulator is so realistic that you can hardly tell the difference between the simulator and the real aircraft. Modelled after the popular Cessna 172 Skyhawk, all details are precisely reproduced according to the exact dimensions of the original panel and they can be found in exactly the same position. Using gauges modelled after the original, and designed to be driven from a Personal Computer, the SASA-172 is the ultimate training device for pilots. The SASA-172 is a product out of a complete line of training devices, and comes complete with Professional Rudder Pedals. An additional cockpit enclosure, visual and motion base are optional. Training with the SASA-172 is extremely close to reality, but much more economic and fun.

The SASA-172's gauges are modelled after the original gauges found in the Cessna 172 Skyhawk. They are not projected on an LCD screen like other flight simulators, but instead real instruments which feels and looks are just like the original instruments. They are redesigned from scratch to be driven from flight simulator software residing on the Personal Computer, utilizing servo motors and digital electronics. The exact position of the gauges on the panel boosts the important "panel scan" experience, so that once in the real aircraft, your attention can be fully focussed on flying safely.

The SASA-172 is built up to FAA/Canadian Transport/JAA and JAA so-called specifications. Therefore approvals can be achieved easy (additional Pro License Fee applies).

From the moment you start the engine the adventure begins! The key lock starter switch has the original 5-positions off, right, left, on and start. All switches are fully functional. Even the circuit breakers will pop out under control of an instructor, to introduce failures for realistic flight training. The realism of SASA's flight training device gives you the thrill of flying in the real aircraft. Trim Wheel (with indicator), Throttle, Mixture with real leaning positioning (fine tuning) and the Flap Switch, with servo controlled Trim Indicator, enable you to experience flight training so realistic that you will become a better pilot.

We Sell SASA-172 around the world. From Japan to the USA, from Finland to South Africa, from the UK to Sout America. It's real. It's fun!

Navirnet S.L.
39529 Ruiseñada,
Comillas, Cantabria.
Tel/Fax: +34 942722059
navirnet@navirnet.net



NAVIRNET SL - SPAIN

www.navirnet.net

There are 4 versions of the SASA-172 available:

- The SASA-172 Full Kit (built it yourself)
- The SASA-172M (ready to fly, personal use only)
- The SASA-172NG (ready to fly, commercial/training use allowed)
- The SASA-172F (ready to fly, JAA/FNPT1 and FAA approved) (Ask for more information)

Professional/commercial use

As the SASA-172 is built to approvable specifications, it can be certified by your local authorities. When the SASA-172 is purchased with the intention to use it commercially (either for flight training or other commercial purposes, any other use than personal) an additional fee for the commercial use is applicable. Therefore in such cases the SASA-172 must be ordered as "SASA-172NG" which includes Commercial License. In case the SASA-172 is ordered as a non-commercial version and will be used at any later time for commercial purposes the purchase of a separate "Commercial License Fee" which covers the difference between the "M" version and the "C-NG" version is required prior to commercial use.

The full kit

The kit includes all parts to built a complete flight deck. All parts are in kit form, except the following instruments which are only available as built and tested: Wet Compass, all Radio Stack Modules, the CCU, the Radio Stack Controller and the Professional Rudder Pedals.

The final product, after you have built it, may only be used for personal training by the purchaser of the product.

It may not be purchased with the intention to resell it to other parties without the written approval Lu'um Air Development.

When the kit is used to built a product which will be used professionally (either for flight training or other commercial purposes) an additional fee for the commercial use is applicable and the purchase of a separate "Commercial License Fee" is required prior to commercial use.

Navirnet S.L.
39529 Ruiseñada,
Comillas, Cantabria.
Tel/Fax: +34 942722059
navirnet@navirnet.net